



SYSTEMS

Porte d'ingresso  
Entrance doors







# Indice

## Index

Il nostro ecosistema	<i>Our ecosystem</i>	p. 03
8 buone ragioni	<i>8 good reasons</i>	p. 04
Ecosostenibilità	<i>Eco-sustainability</i>	p. 08
Porte d'ingresso	<i>Entrance doors</i>	
• Forme estetiche	• <i>Aesthetic shapes</i>	p. 13
• Gli accessori	• <i>The accessories</i>	p. 14
• Tipologie di aperture	• <i>Opening typologies</i>	p. 16
• Serie porte d'ingresso	• <i>Entrance doors series</i>	p. 18
Le nostre soluzioni	<i>Our solutions</i>	p. 22
• Pannello Classico	• <i>Classic panel</i>	p. 25
• Pannello Fresato	• <i>Milled panel</i>	p. 31
• Vetro	• <i>Glass</i>	p. 37
Tecnologia	<i>Technology</i>	p. 42
Posa Clima	<i>Posa Clima</i>	p. 44
Prestazioni	<i>Prestazioni</i>	p. 46



# Il nostro ecosistema

## Our ecosystem

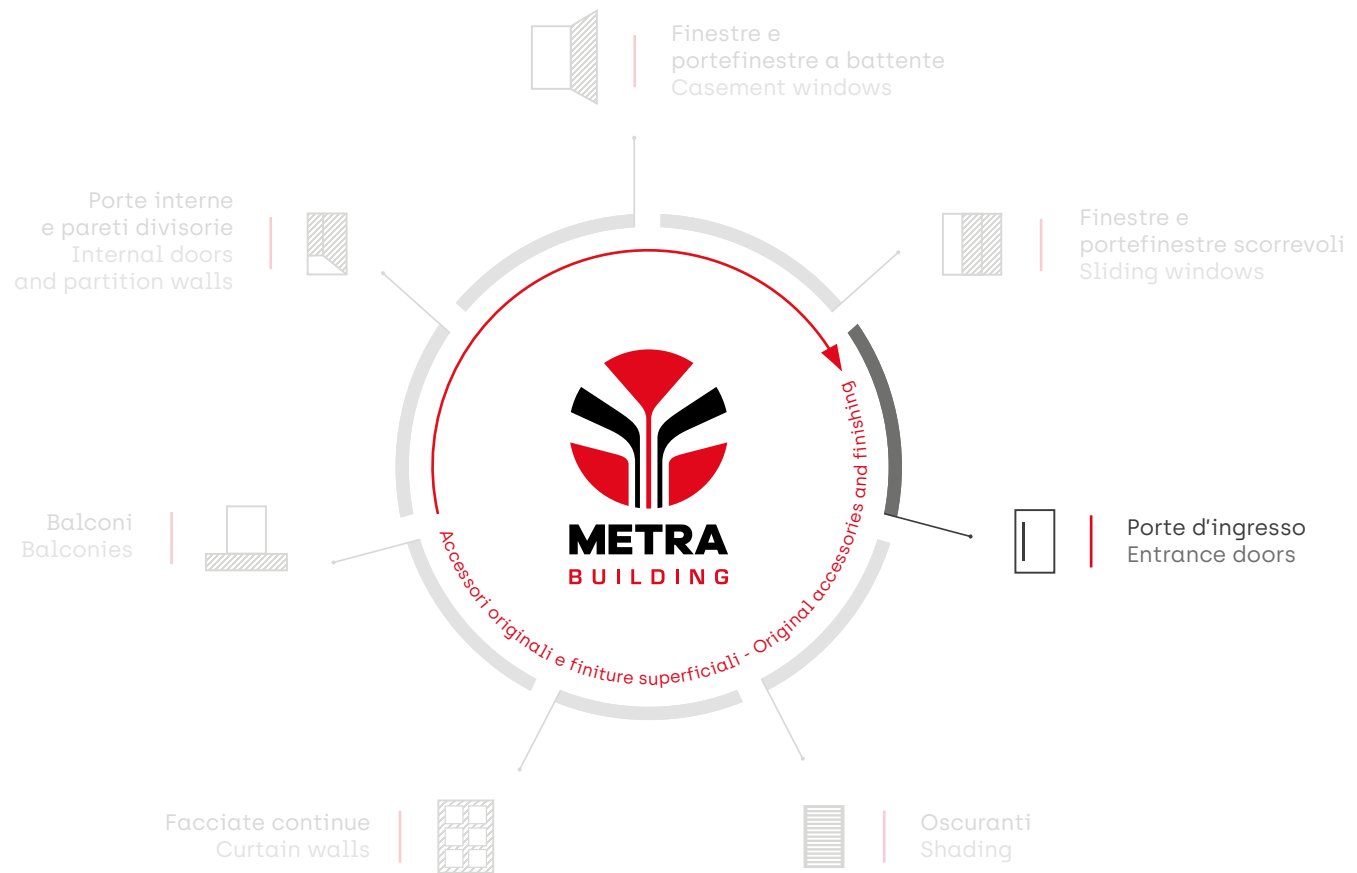

Qualità certificata  
Certified quality





# Serramenti in alluminio METRA Building: 8 buone ragioni

METRA Building Aluminium windows and doors: 8 good reasons

## Essenziale e luminoso

Essential and bright



Geometrie compatte che consentono di recuperare luminosità negli spazi. La tecnologia giunge ai suoi massimi livelli e si condensa fino a soli 63 mm (2-1/2") di spessore. La bellezza si traduce in design e si completa con accessori a scomparsa e maniglie minimali.

---

*Compact geometries that allow to recover brightness in spaces. The technology reaches its maximum level and condenses to a thickness of only 63 mm (2-1/2"). Beauty translates into design and is completed with concealed accessories and minimalist handles.*

## Praticamente eterni

Practically eternal



Resistenza meccanica, stabilità, robustezza e manutenzione ridotta ai minimi termini. Numerose qualità e straordinari vantaggi in un unico materiale in grado di durare per sempre.

---

*Mechanical resistance, stability, robustness and maintenance reduced at the minimum. Numerous qualities and extraordinary advantages in a single material able to last forever.*

## Isolamento termico e acustico da classe Gold

### Gold class thermal and acoustic insulation



Con la tecnologia HES (High Energy Saving) l'isolamento termico è ai massimi livelli prestazionali. La riduzione dei costi energetici nel riscaldamento e raffreddamento è assicurata, così come il comfort abitativo reso ancor più elevato dal perfetto isolamento acustico.

---

*With HES (High Energy Saving) technology thermal insulation is at the highest performance levels. The reduction of energy costs in heating and cooling is ensured, as well as the living comfort made even higher by perfect sound insulation.*

## Sonni tranquilli

### Sleep soundly



Sicurezza garantita con i sistemi antieffrazione in classe RC2 e RC3 (standard europei). un sistema di chiusura perimetrale fino a 16 punti (predisposizione antifurto) capace di resistere a scassinatori e malintenzionati.

---

*Guaranteed security with class RC2 and RC3 (European standards) burglar-proof systems. a perimeter locking system with up to 16 points (anti-theft predisposition) able to resist burglars and malicious intruders.*





## Tutti i colori della performance

### All colours of performance

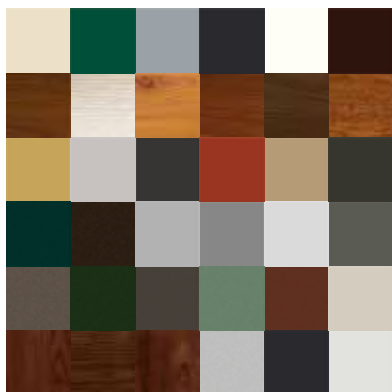

Spazio alla fantasia nella scelta dei colori. Verniciatura a polvere o liquida. Finiture ossidate, verniciature opache, lucide, extralucide e trattamenti effetto legno a marchio Qualanod-Qualicoat-Seaside-Qualideco anche con opzione antibatterica. Durata assicurata fino a 30 anni. Disponibile AAMA 2603, 2604 e 2605.

---

*Space for imagination in the choice of colours. Powder or liquid coating. Oxidised finishes, matt, gloss, high-gloss and wood-effect treatments under the Qualanod-Qualicoat-Seaside-Qualideco brand also with antibacterial option. Guaranteed durability up to 30 years. AAMA 2603, 2604 and 2605 available.*

## Più spazio al movimento

### More space for movement

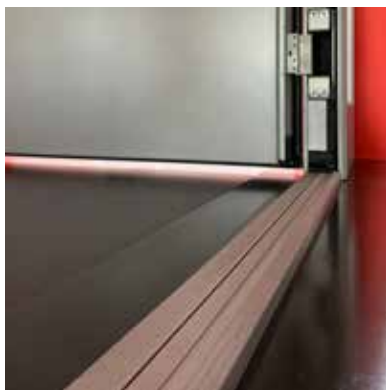

Estetica e accessibilità in un unico sistema che abbatte le barriere architettoniche e consente facili accessi. Con la soglia ribassata gli ostacoli si riducono al minimo.

---

*Aesthetics and accessibility in a single system that breaks down architectural barriers and allows easy access. With the lowered threshold, obstacles are reduced to a minimum.*



## Sistema integrato perfetto

Perfect integrated system

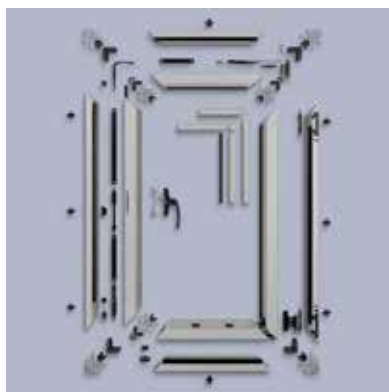

Maniglie, meccanismi di apertura e chiusura, cerniere, guarnizioni e squadrette: tutti gli accessori coordinati, rigorosamente originali METRA Building, si fondono con il serramento per garantire i migliori risultati.

---

*Handles, opening and closing devices, hinges, gaskets and corner cleats: all matching accessories, rigorously METRA Building original, blend with the window or door to guarantee the best results.*

## Eccellenza italiana

Italian excellence



Tutti i serramenti METRA Building sono estrusi in Italia e Nord America e rispondono alle più selettive certificazioni internazionali. I migliori processi produttivi integrati, uniti a oltre 60 anni di know-how, per creare un prodotto bello, sicuro e dalle prestazioni inimitabili.

---

*All METRA Building windows and doors are extruded in Italy and North America and meet the most selective international certifications. The best integrated production processes, combined with over 60 years of know-how, to create a beautiful and safe product with inimitable performance.*

I nostri profili in alluminio sono presenti in alcune delle più prestigiose realizzazioni al mondo: dalla iconica Piramide del Louvre, alle torri di New York fino agli avveniristici grattacieli di Dubai.

*Our aluminium profiles are featured in some of the most prestigious projects in the world: from the iconic Louvre Pyramid to the towers of New York and the futuristic skyscrapers of Dubai.*



# Ecosostenibilità

## Eco-sustainability

L'alluminio è una scelta sostenibile per gli edifici: ha un'elevata durabilità, ridotta manutenzione e può essere riciclato al 100% e all'infinito, senza perdere le sue proprietà.

L'attenzione per la riduzione dell'impatto ambientale di Metra riguarda tutta la catena del valore dell'alluminio, grazie all'elevato contenuto di materiale riciclato nei profili e l'assenza di VOC, che si concretizza nelle certificazioni ambientali (EPD) ottenute sui prodotti.

Metra Building mette a disposizione un portafoglio di soluzioni per garantire una progettazione sostenibile a basso impatto ambientale, che garantiscono efficienza energetica e favoriscono l'utilizzo della luce naturale, in linea con i requisiti dei protocolli LEED, BREEAM, DGNB e il rispetto dei Criteri Ambientali Minimi.

*Aluminium is a sustainable choice for buildings: it has high durability, low maintenance and can be recycled 100% and infinitely without losing its properties.*

*The attention to reducing Metra's environmental impact concerns the entire aluminium value chain, thanks to the high content of recycled material in the profiles and the absence of VOCs, which is reflected in the environmental certifications (EPD) obtained on the products.*

*Metra Building offers a portfolio of solutions to guarantee sustainable design with low environmental impact, which guarantee energy efficiency and support the use of natural light, in line with the requirements of LEED, BREEAM, DGNB protocols and compliance with Minimum Environmental Criteria.*











# Porte d'ingresso

Entrance doors













# Forme estetiche

## Aesthetic shapes

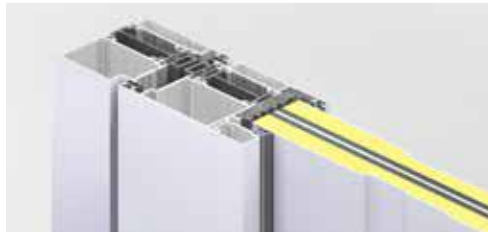

Piana / Basic

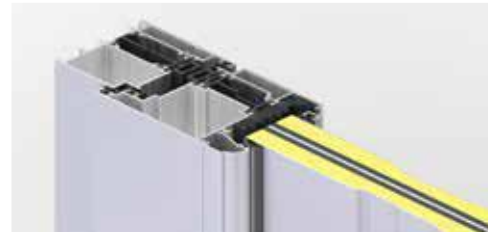

Sagomata / Shaped



# Gli accessori originali METRA Building

## The METRA Building original accessories

a	<b>Cerniera a scomparsa</b> <b>Concealed hinge</b>	Materiali, progettazione e sicurezza per un'estetica essenziale dal design innovativo e di grande impatto.  <i>Materials, design and safety for an essential aesthetic with an innovative, high-impact design.</i>
b	<b>Maniglioni</b> <b>Handles</b>	Eleganza, robustezza, versatilità e ampia gamma proposta con diverse misure e forme geometriche.  <i>Elegance, durability, versatility and a wide range of different sizes and geometric shapes.</i>
c	<b>Serratura di sicurezza</b> <b>Security lock</b>	Sistemi innovativi per alti standard anti-effrazione e soluzioni ottimali contro il bi-metal effect.  <i>Innovative systems for high burglar-proof standards and optimal solutions against the bi-metal effect.</i>
d	<b>Soglia ribassata con tappi di tenuta</b> <b>Low sill with tightness caps</b>	Più spazio al movimento nel rispetto del design. Robustezza, sicurezza ed isolamento termico in un'unica soluzione.  <i>More space for movement while respecting the design. Durability, safety and thermal insulation in one solution.</i>
e	<b>Chiudiporta a scomparsa</b> <b>Concealed door closer</b>	Completamente nascosto, regola la forza, la velocità di chiusura e la resistenza di apertura della porta. La durabilità e la sicurezza delle nostre porte sempre al centro.  <i>Completely concealed, it regulates the force, closing speed and opening resistance of the door. The durability and safety of our doors always comes first.</i>
f	<b>Pannelli</b> <b>Panels</b>	Lavorazioni e finiture con pannelli classici o fresati per soddisfare le molteplici esigenze estetiche, dalle più tradizionali a quelle più moderne.  <i>Machining and finishing with classic or milled panels to meet a variety of aesthetic requirements, from the most traditional to the most modern.</i>







# Tipologie di aperture

## Opening typologies

Porte d'ingresso  
Entrance doors

---

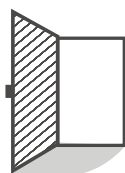

1 anta ad apertura interna  
*Single-leaf outward opening*

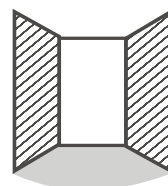

2 ante apertura interna  
*Double-leaf inward opening*



1 anta ad apertura esterna  
*Single-leaf outward opening*



2 ante apertura esterna  
*Double-leaf outward opening*



1 anta ad apertura esterna antipanico  
*Single-leaf outward opening emergency exit*



2 ante apertura esterna antipanico  
*Double-leaf outward opening emergency exit*





# Porte d'ingresso

## Entrance doors

Le porte d'ingresso a battente METRA Building sono un vero concentrato di design e tecnologia, ideali per le abitazioni private e per gli edifici pubblici e in abbinamento con i sistemi integrati per facciate continue.

Molteplici le finiture disponibili, colori ed effetti progettati per incontrare diversi stili e gusti.

Completa l'estetica delle porte d'ingresso METRA Building l'ampia scelta dei tagli di luce da associare ai vetri e una selezione di accessori originali dal design unico. Grazie alla doppia o tripla guarnizione garantiscono un'eccellente tenuta agli agenti atmosferici e massime prestazioni in termini di risparmio energetico e isolamento termico e acustico.

Robuste e senza tempo, le porte d'ingresso METRA Building garantiscono la massima sicurezza e richiedono una manutenzione minima.

Due le linee estetiche disponibili:

- **Piana**

Semplicità e linearità ideali per gli ambienti in stile moderno e minimalista

- **Sagomata**

Dal sapore più classico, adatta allo stile tradizionale.

*METRA Building entrance doors are a real concentrate of design and technology, ideal for private homes and public buildings and in combination with integrated curtain wall systems. Many finishes are available, colours and effects designed to meet different styles and tastes. The aesthetics of METRA Building entrance doors are completed by the wide choice of light sections to be associated with glass and a selection of original accessories with a unique design. Thanks to the double or triple gasket they guarantee excellent resistance to atmospheric agents and maximum performance in terms of energy saving and thermal and acoustic insulation.*

*Robust and timeless, METRA Building entrance doors guarantee maximum security and require minimum maintenance.*

*Two aesthetic lines are available:*

- **Basic line**

*Simplicity and linearity ideal for modern and minimalist style environments*

- **Shaped line**

*With a more classic flavour, adapted to the traditional style.*







Porte d'ingresso  
Entrance doors

Le serie  
Series

## SERIE / SERIES NC 90 HES

### NC 90 HES DS

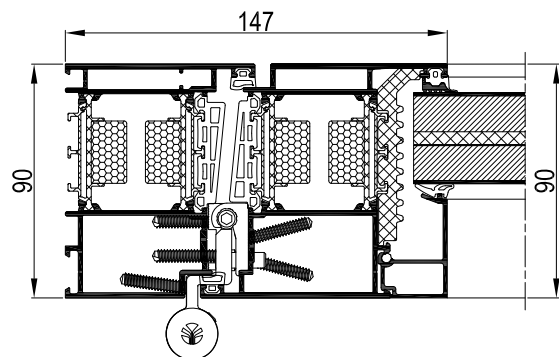

Telaio fisso <i>Frame</i>	Telaio mobile <i>Sash</i>	Spessore pannello classico <i>Classic panel thickness</i>
90 mm	90 mm	da 7 mm a 42 mm <i>from 7 mm to 42 mm</i>

### NC 90 HES DL

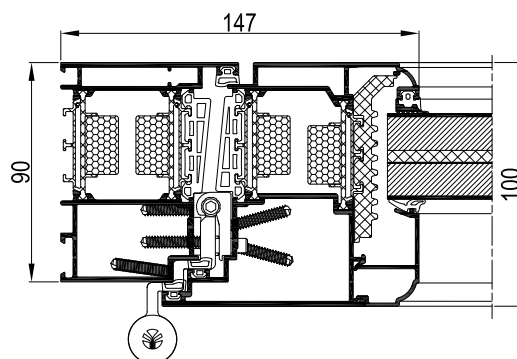

Telaio fisso <i>Frame</i>	Telaio mobile <i>Sash</i>	Spessore pannello classico <i>Classic panel thickness</i>
90 mm	100 mm	da 7 mm a 42 mm <i>from 7 mm to 42 mm</i>

## SERIE / SERIES NC 65 HES

### NC 65 HES DS

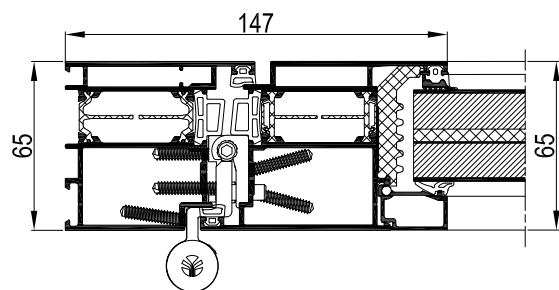

Telaio fisso <i>Frame</i>	Telaio mobile <i>Sash</i>	Spessore pannello classico <i>Classic panel thickness</i>
65 mm	65 mm	da 7 mm a 42 mm <i>from 7 mm to 42 mm</i>

### NC 65 HES DL

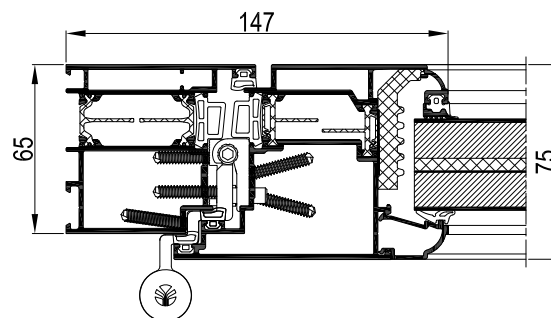

Telaio fisso <i>Frame</i>	Telaio mobile <i>Sash</i>	Spessore pannello classico <i>Classic panel thickness</i>
65 mm	75 mm	da 7 mm a 35 mm <i>from 7 mm to 35 mm</i>

## SERIE / SERIES NC 75 HES

### NC 75 HES DS

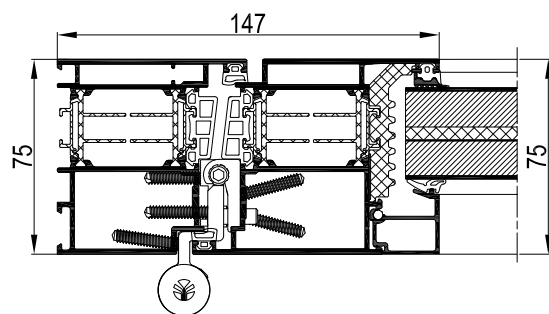

Telaio fisso <i>Frame</i>	Telaio mobile <i>Sash</i>	Spessore pannello classico <i>Classic panel thickness</i>
75 mm	75 mm	da 7 mm a 42 mm <i>from 7 mm to 42 mm</i>

### NC 75 HES DL

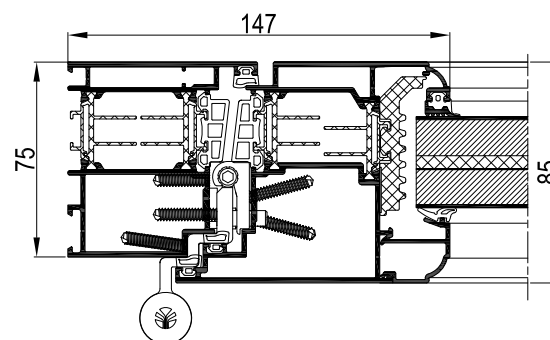

Telaio fisso <i>Frame</i>	Telaio mobile <i>Sash</i>	Spessore pannello classico <i>Classic panel thickness</i>
75 mm	85 mm	da 7 mm a 42 mm <i>from 7 mm to 42 mm</i>

## ALTRE SOLUZIONI / OTHER SOLUTIONS

### NC 50 I DS

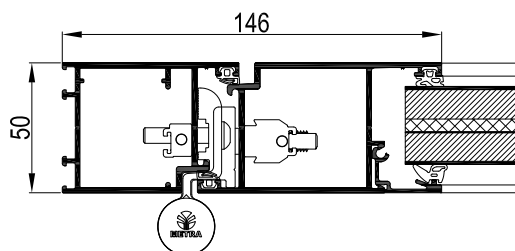

Telaio fisso <i>Frame</i>	Telaio mobile <i>Sash</i>	Spessore pannello classico <i>Classic panel thickness</i>
50 mm	50 mm	da 7 mm a 31 mm <i>from 7 mm to 31 mm</i>

### NC 50 STH DS

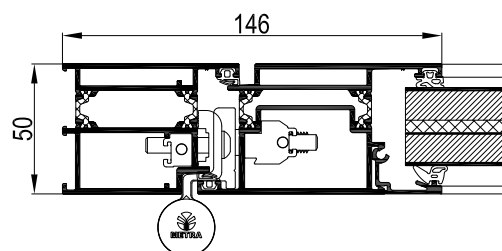

Telaio fisso <i>Frame</i>	Telaio mobile <i>Sash</i>	Spessore pannello classico <i>Classic panel thickness</i>
50 mm	50 mm	da 7 mm a 31 mm <i>from 7 mm to 31 mm</i>





Porte d'ingresso  
Entrance doors

# Le nostre soluzioni

## Our solutions



Pannello Classico  
Classic panel



Pannello Fresato  
Milled panel



Vetro  
Glass



Pannello Classico  
Classic panel



Pannello Fresato  
Milled panel



Vetro  
Glass







Porte d'ingresso  
Entrance doors

## Pannello Classico Classic panel







15



27





Porte d'ingresso  
Entrance doors

Pannello Classico  
Classic panel

## SERIE / SERIES NC 90 HES

### NC 90 HES DS

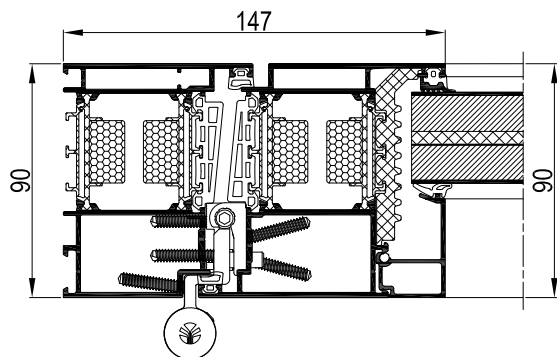

Telaio fisso <i>Frame</i>	Telaio mobile <i>Sash</i>	Spessore pannello classico <i>Classic panel thickness</i>
90 mm	90 mm	da 7 mm a 42 mm <i>from 7 mm to 42 mm</i>

### NC 90 HES DL

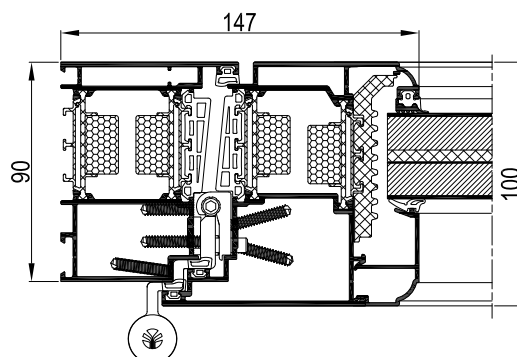

Telaio fisso <i>Frame</i>	Telaio mobile <i>Sash</i>	Spessore pannello classico <i>Classic panel thickness</i>
90 mm	100 mm	da 7 mm a 42 mm <i>from 7 mm to 42 mm</i>

## SERIE / SERIE NC 75 HES

### NC 75 HES DS

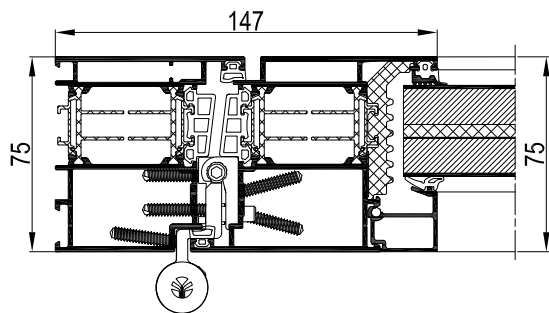

Telaio fisso <i>Frame</i>	Telaio mobile <i>Sash</i>	Spessore pannello classico <i>Classic panel thickness</i>
75 mm	75 mm	da 7 mm a 42 mm <i>from 7 mm to 42 mm</i>

### NC 75 HES DL

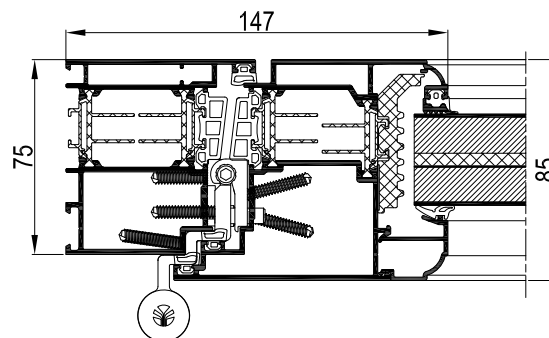

Telaio fisso <i>Frame</i>	Telaio mobile <i>Sash</i>	Spessore pannello classico <i>Classic panel thickness</i>
75 mm	85 mm	da 7 mm a 42 mm <i>from 7 mm to 42 mm</i>

## SERIE / SERIES NC 65 HES

### NC 65 HES DS

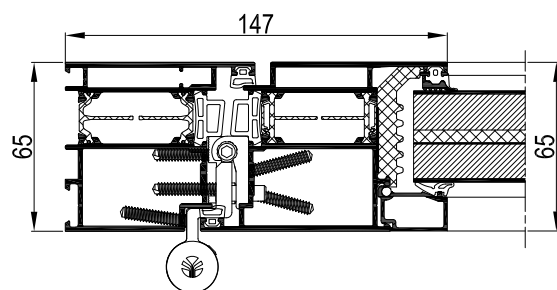

Telaio fisso <i>Frame</i>	Telaio mobile <i>Sash</i>	Spessore pannello classico <i>Classic panel thickness</i>
65 mm	65 mm	da 7 mm a 42 mm <i>from 7 mm to 42 mm</i>

### NC 65 HES DL

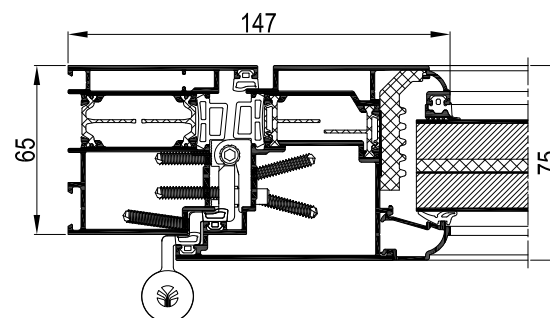

Telaio fisso <i>Frame</i>	Telaio mobile <i>Sash</i>	Spessore pannello classico <i>Classic panel thickness</i>
65 mm	75 mm	da 7 mm a 35 mm <i>from 7 mm to 35 mm</i>

## ALTRE SOLUZIONI / OTHER SOLUTIONS

### NC 50 I DS

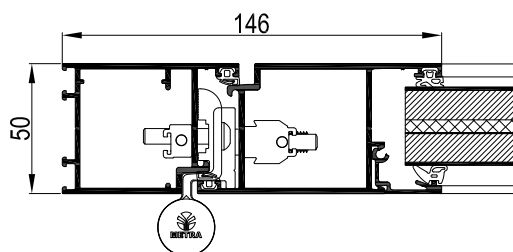

Telaio fisso <i>Frame</i>	Telaio mobile <i>Sash</i>	Spessore pannello classico <i>Classic panel thickness</i>
50 mm	50 mm	da 7 mm a 31 mm <i>from 7 mm to 31 mm</i>

### NC 50 STH DS

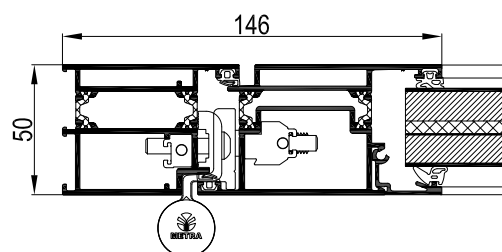

Telaio fisso <i>Frame</i>	Telaio mobile <i>Sash</i>	Spessore pannello classico <i>Classic panel thickness</i>
50 mm	50 mm	da 7 mm a 31 mm <i>from 7 mm to 31 mm</i>







Porte d'ingresso  
Entrance doors

Pannello Fresato  
Milled panel









Porte d'ingresso  
Entrance doors

Pannello Fresato  
Milled panel

## SERIE / SERIES NC 90 HES

### NC 90 HES DS

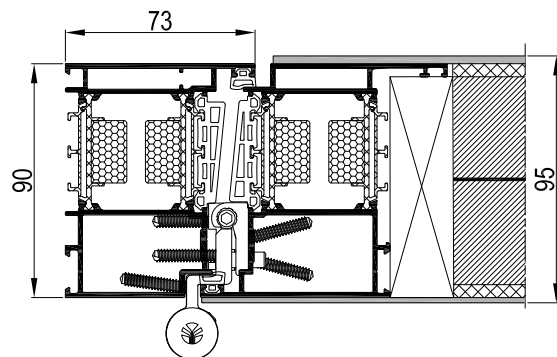

Telaio fisso <i>Frame</i>	Telaio mobile <i>Sash</i>	Spessore pannello fresato <i>Milled panel thickness</i>
90 mm	90 mm	95 mm

### NC 90 HES DL

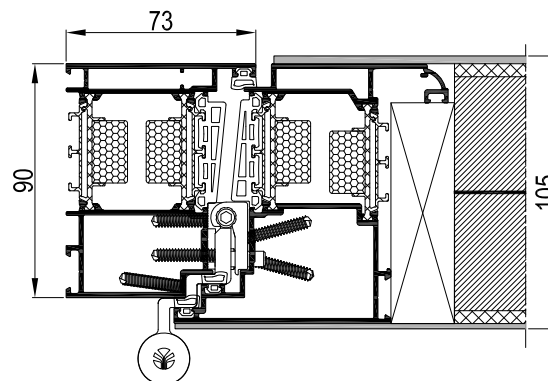

Telaio fisso <i>Frame</i>	Telaio mobile <i>Sash</i>	Spessore pannello fresato <i>Milled panel thickness</i>
90 mm	100 mm	105 mm

## SERIE / SERIE NC 75 HES

### NC 75 HES DS

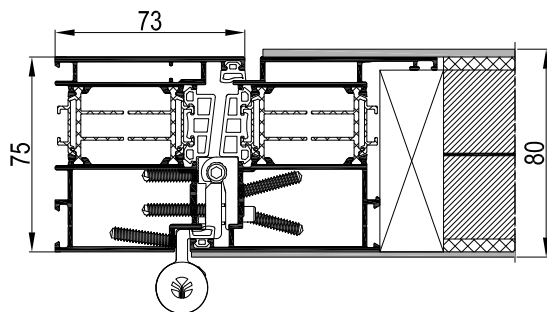

Telaio fisso <i>Frame</i>	Telaio mobile <i>Sash</i>	Spessore pannello fresato <i>Milled panel thickness</i>
75 mm	75 mm	80 mm

### NC 75 HES DL

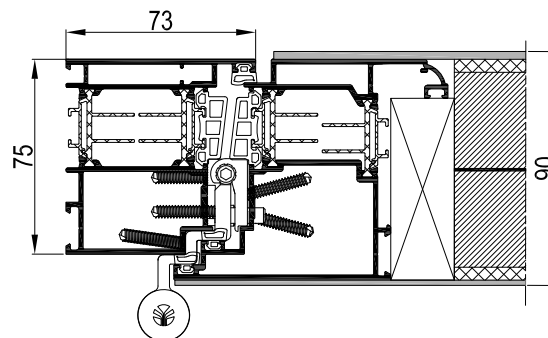

Telaio fisso <i>Frame</i>	Telaio mobile <i>Sash</i>	Spessore pannello fresato <i>Milled panel thickness</i>
75 mm	85 mm	90 mm

## SERIE / SERIES NC 65 HES

### NC 65 HES DS

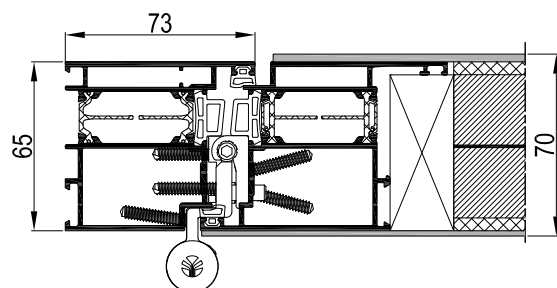

Telaio fisso <i>Frame</i>	Telaio mobile <i>Sash</i>	Spessore pannello fresato <i>Milled panel thickness</i>
65 mm	65 mm	48 mm (pannello 1 faccia) o 70 mm (pannello doppia faccia) <i>48 mm (1-sided panel) or 70 mm (Double-sided panel)</i>

### NC 65 HES DL

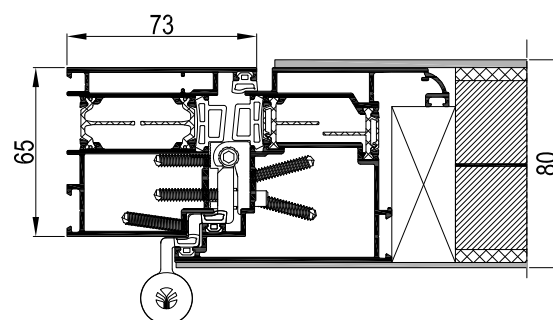

Telaio fisso <i>Frame</i>	Telaio mobile <i>Sash</i>	Spessore pannello fresato <i>Milled panel thickness</i>
65 mm	75 mm	80 mm







Porte d'ingresso  
Entrance doors

Vetro  
Glass

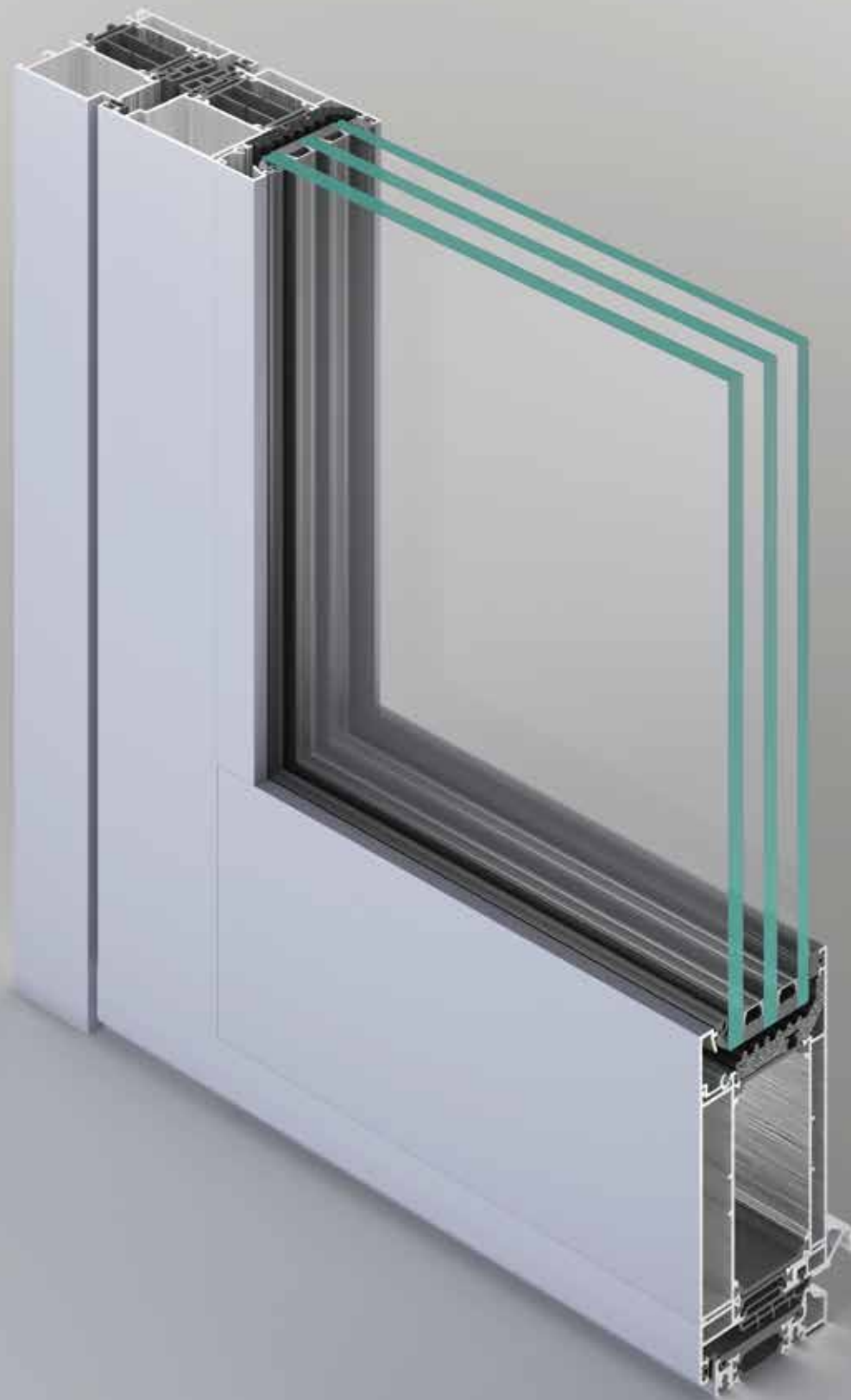







Porte d'ingresso  
Entrance doors

Vetro  
Glass

## SERIE / SERIES NC 90 HES

### NC 90 HES DS

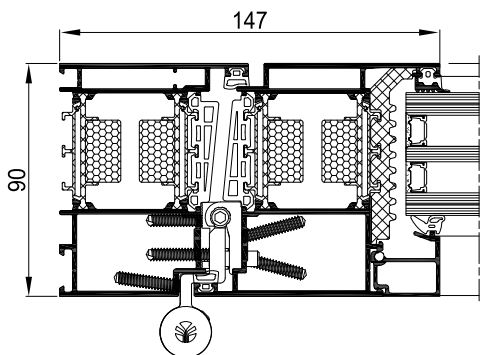

Telaio fisso <i>Frame</i>	Telaio mobile <i>Sash</i>	Spessore vetri <i>Glass thickness</i>
90 mm	90 mm	da 12 mm a 73 mm <i>from 12 mm to 73 mm</i>

### NC 90 HES DL

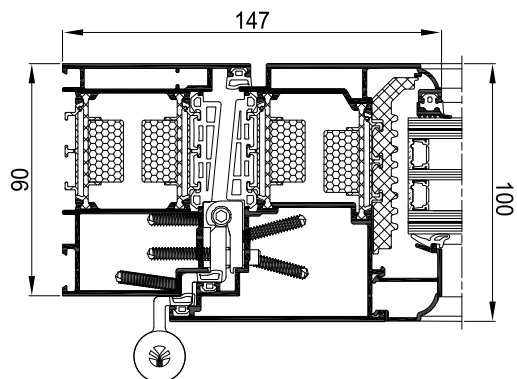

Telaio fisso <i>Frame</i>	Telaio mobile <i>Sash</i>	Spessore vetri <i>Glass thickness</i>
90 mm	100 mm	da 27 mm a 61 mm <i>from 27 mm to 61 mm</i>

## SERIE / SERIE NC 75 HES

### NC 75 HES DS

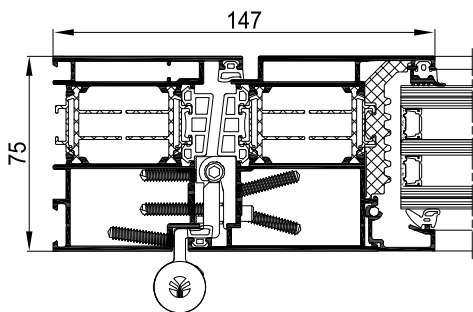

Telaio fisso <i>Frame</i>	Telaio mobile <i>Sash</i>	Spessore vetri <i>Glass thickness</i>
75 mm	75 mm	da 18 mm a 60 mm <i>from 18 mm to 60 mm</i>

### NC 75 HES DL

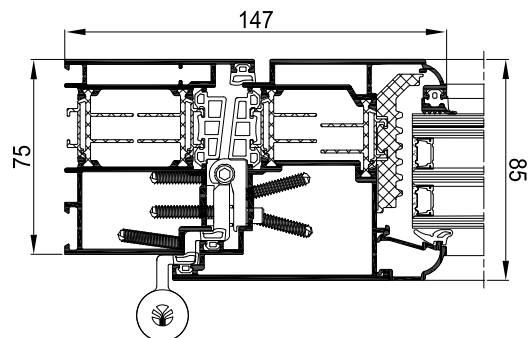

Telaio fisso <i>Frame</i>	Telaio mobile <i>Sash</i>	Spessore vetri <i>Glass thickness</i>
75 mm	85 mm	da 18 mm a 48 mm <i>from 18 mm to 48 mm</i>

## SERIE / SERIES NC 65 HES

### NC 65 HES DS

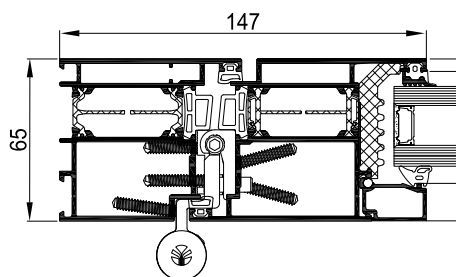

Telaio fisso <i>Frame</i>	Telaio mobile <i>Sash</i>	Spessore vetri <i>Glass thickness</i>
65 mm	65 mm	da 8 mm a 50 mm <i>from 8 mm to 50 mm</i>

### NC 65 HES DL

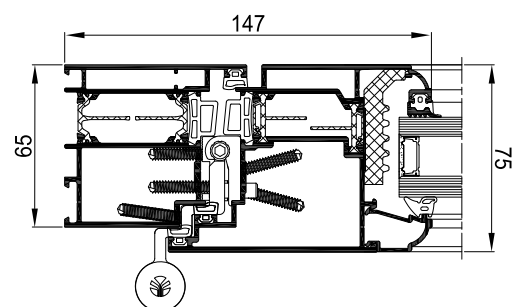

Telaio fisso <i>Frame</i>	Telaio mobile <i>Sash</i>	Spessore vetri <i>Glass thickness</i>
65 mm	75 mm	da 8 mm a 38 mm <i>from 8 mm to 38 mm</i>

## ALTRE SOLUZIONI / OTHER SOLUTIONS

### NC 50 I DS

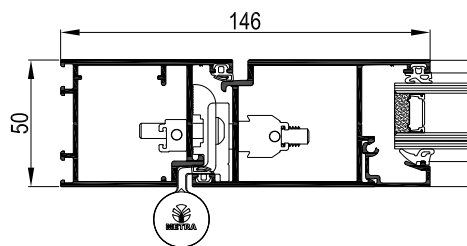

Telaio fisso <i>Frame</i>	Telaio mobile <i>Sash</i>	Spessore vetri <i>Glass thickness</i>
50 mm	50 mm	da 4 mm a 32 mm <i>from 4 mm to 32 mm</i>

### NC 50 STH DS

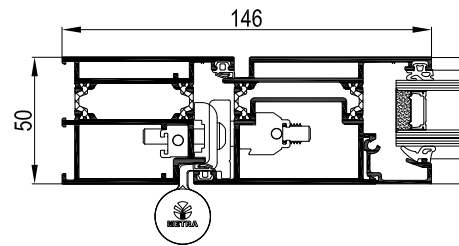

Telaio fisso <i>Frame</i>	Telaio mobile <i>Sash</i>	Spessore vetri <i>Glass thickness</i>
50 mm	50 mm	da 4 mm a 32 mm <i>from 4 mm to 32 mm</i>



# Tecnologia

## Technology

- 1 Pannello
- 2 Guarnizioni per vetro e/o pannello
- 3 Astine termiche
- 4 Guarnizione di tenuta
- 5 Telaio fisso
- 6 Fermavetro
- 7 Telaio mobile
- 8 Profilo di battuta soglia
- 9 Zoccolo

- 
- 1 *Panel*
  - 2 *Gasket for glazing and/or panel*
  - 3 *Insulating bars*
  - 4 *Tightness gasket*
  - 5 *Frame*
  - 6 *Glazing bead*
  - 7 *Sash*
  - 8 *Sill rabbet profile*
  - 9 *Base transom*

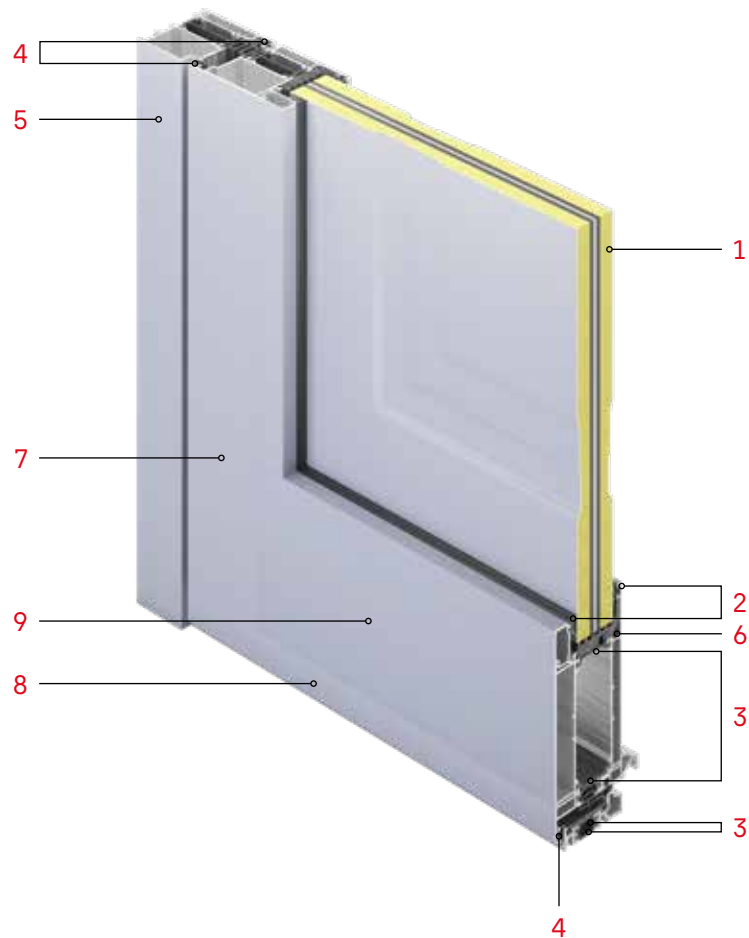







# Posa Clima: L'importanza della posa in opera

## Posa Clima: the importance of installation

L'innovativo sistema di posa firmato METRA assicura all'edificio un totale comfort termo-acustico e un importante risparmio energetico.

Posa Clima è applicabile a tutti i prodotti METRA Building e offre altri vantaggi:

- è riciclabile
- è libero da stabilizzanti al piombo e altri metalli pesanti
- garantisce ottima resistenza agli agenti atmosferici e all'invecchiamento, anche con esposizione al sole, alla salsedine e ai più comuni agenti chimici
- è ignifugo e si autoestingue
- è facilmente verniciabile

*The innovative installation system signed METRA ensures the building a total thermal-acoustic comfort and a important energy saving.*

*Posa Clima is applicable to all METRA Building products and offers other advantages:*

- *recyclable*
- *free of lead stabilisers and other heavy metals*
- *guarantees excellent resistance to atmospheric agents and ageing, even with exposure to the sun, salt and the most common chemical agents*
- *fireproof and self-extinguishing*
- *easy to paint*

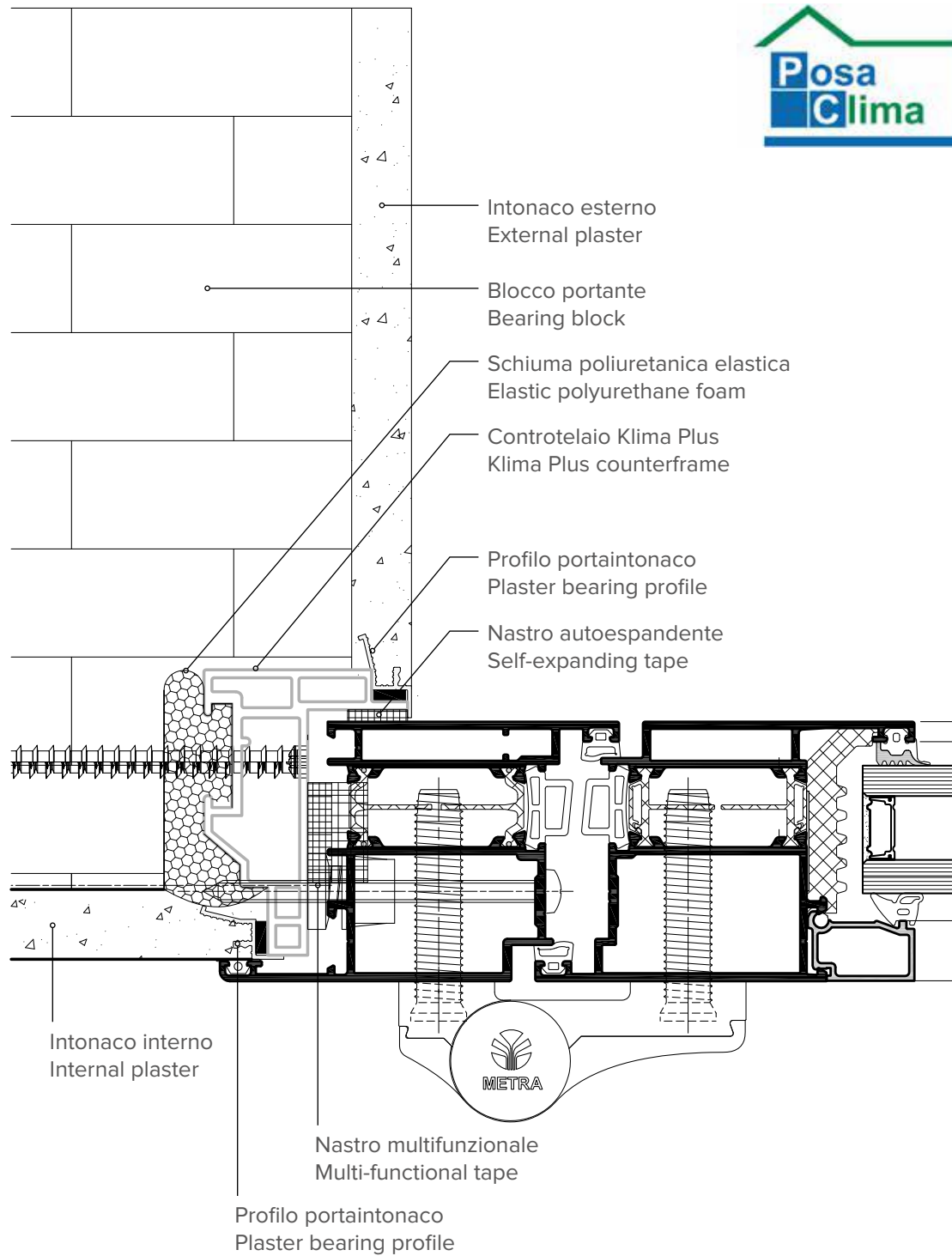





## Prestazioni Performances

1 ANTA AD APERTURA INTERNA SINGLE-LEAF OUTWARD OPENING	Linea Classica / Linea Fresata / Linea Origini Classic line / Milled line / Origins Line					
	90		75		65	
	DS	DL	DS	DL	DS	DL
Permeabilità all'aria Air permeability EN 1026 - EN 12207	4					
Tenuta all'acqua Water tightness EN 1027 - EN 12208	7A					
Resistenza al vento Resistance to wind load EN 12211 - EN 12210	B5/C5					
Potere fonoisolante Soundproofing power EN ISO 10140-3 EN ISO 717-1	fino a 42dB					
Forze di azionamento Operating forces EN 13115	2					
Resistenza meccanica Mechanical resistance EN 12046 - EN 13115	3					
Resistenza all'effrazione Burglar resistance EN 1627 - EN 1630	RC2					
Resistenza ai cicli di apertura e chiusura Resistance to repeated opening and closing cycles EN 1191 - EN 12400	Classe 5 N° cicli: 100.000					
Resistenza all'urto Resistance to impact EN 13049	4					
Trasmittanza termica Thermal transmittance	0,69 - 1,6		1,4 - 3,0		1,4 - 2,7	
Uf W/m² K	0,69 - 1,6		1,4 - 3,0		1,4 - 2,7	
Ud W/m² K	0,8		1,3		1,4	
Porta / door 1230 x 2180	Ug 0,6 W/m²K, Psi 0,036 W/mK		Ug 1,0 W/m²K, Psi 0,036 W/mK		Ug 1,0 W/m²K, Psi 0,036 W/mK	

1 ANTA AD APERTURA ESTERNA SINGLE-LEAF OUTWARD OPENING	Linea Classica / Linea Fresata / Linea Origini Classic line / Milled line / Origins Line		
	90	75	65
	DS	DS	DS
Permeabilità all'aria Air permeability EN 1026 - EN 12207	4		
Resistenza al vento Resistance to wind load EN 12211 - EN 12210	C5		
Resistenza all'effrazione Burglar resistance EN 1627 - EN 1630	RC2		
Trasmittanza termica Thermal transmittance	0,69 - 1,6	1,4 - 3,0	1,4 - 2,7
Uf W/m² K	0,69 - 1,6	1,4 - 3,0	1,4 - 2,7
Ud W/m² K	0,8	1,3	1,4
Porta / door 1230 x 2180	Ug 0,6 W/m²K, Psi 0,036 W/mK	Ug 1,0 W/m²K, Psi 0,036 W/mK	Ug 1,0 W/m²K, Psi 0,036 W/mK

1 ANTA AD APERTURA INTERNA SINGLE-LEAF OUTWARD OPENING	Linea Classica / Linea Origini Classic line / Origins Line	
	Altre soluzioni / Other solutions	
	NC 50 STH DS	
Trasmittanza termica Thermal transmittance	2,7 - 3,6	
Uf W/m² K	2,7 - 3,6	
Ud W/m² K	2,0	
Porta / door 1230 x 2180	Ug 1,0 W/m²K, Psi 0,036 W/mK	

	Linea Classica / Linea Fresata / Linea Origini Classic line / Milled line / Origins Line					
	90		75		65	
	DS	DL	DS	DL	DS	DL
<b>2 ANTE APERTURA INTERNA</b> DOUBLE-LEAF INWARD OPENING						
Permeabilità all'aria Air permeability EN 1026 - EN 12207	3					
Tenuta all'acqua Water tightness EN 1027 - EN 12208	3A					
Resistenza al vento Resistance to wind load EN 12211 - EN 12210	B2					
Potere fonoisolante Soundproofing power EN ISO 10140-3 EN ISO 717-1	-					
Forze di azionamento Operating forces EN 13115	-					
Resistenza meccanica Mechanical resistance EN 12046 - EN 13115	-					
Resistenza all'effrazione Burglar resistance EN 1627 - EN 1630	RC2					
Resistenza ai cicli di apertura e chiusura Resistance to repeated opening and closing cycles EN 1191 - EN 12400	-					
Resistenza all'urto Resistance to impact EN 13049	-					
Trasmittanza termica Thermal transmittance						
Uf W/m² K	0,69 - 1,6		1,4 - 3,0		1,4 - 2,7	
Ud W/m² K	0,8		1,3		1,4	
Porta / door 2000 x 2180	Ug 0,6 W/m²K, Psi 0,036 W/mK		Ug 1,0 W/m²K, Psi 0,036 W/mK		Ug 1,0 W/m²K, Psi 0,036 W/mK	

	Linea Classica / Linea Fresata / Linea Origini Classic line / Milled line / Origins Line		
	90	75	65
	DS	DS	DS
<b>2 ANTE APERTURA ESTERNA</b> SINGLE-LEAF OUTWARD OPENING			
Permeabilità all'aria Air permeability EN 1026 - EN 12207	3		
Resistenza al vento Resistance to wind load EN 12211 - EN 12210	B2		
Resistenza all'effrazione Burglar resistance EN 1627 - EN 1630	RC2		
Trasmittanza termica Thermal transmittance			
Uf W/m² K	0,69 - 1,6	1,4 - 3,0	1,4 - 2,7
Ud W/m² K	0,8	1,3	1,4
Porta / door 2000 x 2180	Ug 0,6 W/m²K, Psi 0,036 W/mK	Ug 1,0 W/m²K, Psi 0,036 W/mK	Ug 1,0 W/m²K, Psi 0,036 W/mK

	Linea Classica / Linea Origini Classic line / Origins Line	
	Altre soluzioni / Other solutions	
	NC 50 STH DS	
<b>2 ANTE APERTURA INTERNA</b> DOUBLE-LEAF INWARD OPENING		
<b>2 ANTE APERTURA ESTERNA</b> SINGLE-LEAF OUTWARD OPENING		
Trasmittanza termica Thermal transmittance		
Uf W/m² K	2,7 - 3,6	
Ud W/m² K	2,0	
Porta / door 2000 x 2180	Ug 1,0 W/m²K, Psi 0,036 W/mK	







**METRA S.p.A**

Via Stacca 1,  
25050 - Rodengo Saiano  
Brescia - Italy  
T +39 030 68191  
F +39 030 6819990

[info@metrabuilding.com](mailto:info@metrabuilding.com)

**METRA RAGUSA S.p.A.**

Zona industriale,  
97100 - Ragusa  
Italy  
T +39 0932 660911  
F +39 0932 667224

[info.ragusa@metrabuilding.com](mailto:info.ragusa@metrabuilding.com)

**METRA ALUMINIUM INC.**

2000, boul. Fortin  
Laval, QC H7S 1P3  
Canada  
T (450) 629-4260  
F (450) 629-4227

[info.canada@metrabuilding.com](mailto:info.canada@metrabuilding.com)

**METRA USA**

Waterford Business Park  
5201 Blue Lagoon Drive, Unit #984  
Miami, FL 33126  
USA  
T +1 305-915-0999

[info.usa@metrabuilding.com](mailto:info.usa@metrabuilding.com)



[www.metrabuilding.com](http://www.metrabuilding.com)